

TAB SYSTEM ASSEMBLY INSTRUCTIONS

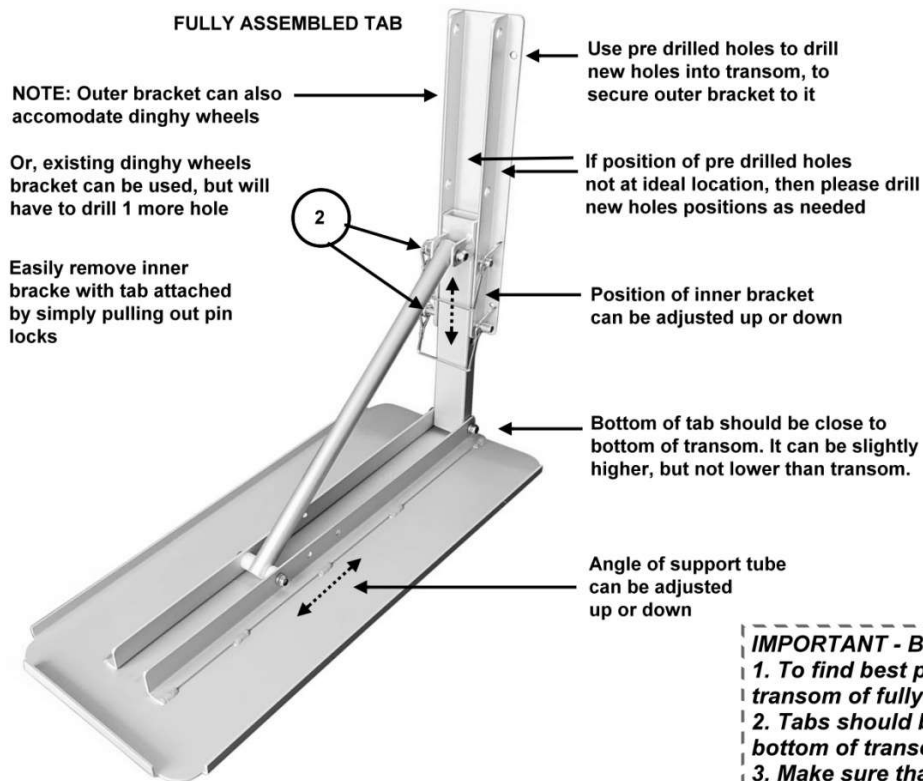

1. Drill 4 to 6 holes in a transom using holes pre drilled in outer bracket. If pre drilled holes position on bracke not at ideal position, then drill new holes in a bracket as needed. Holes could be in a middle of bracket, instead of edges

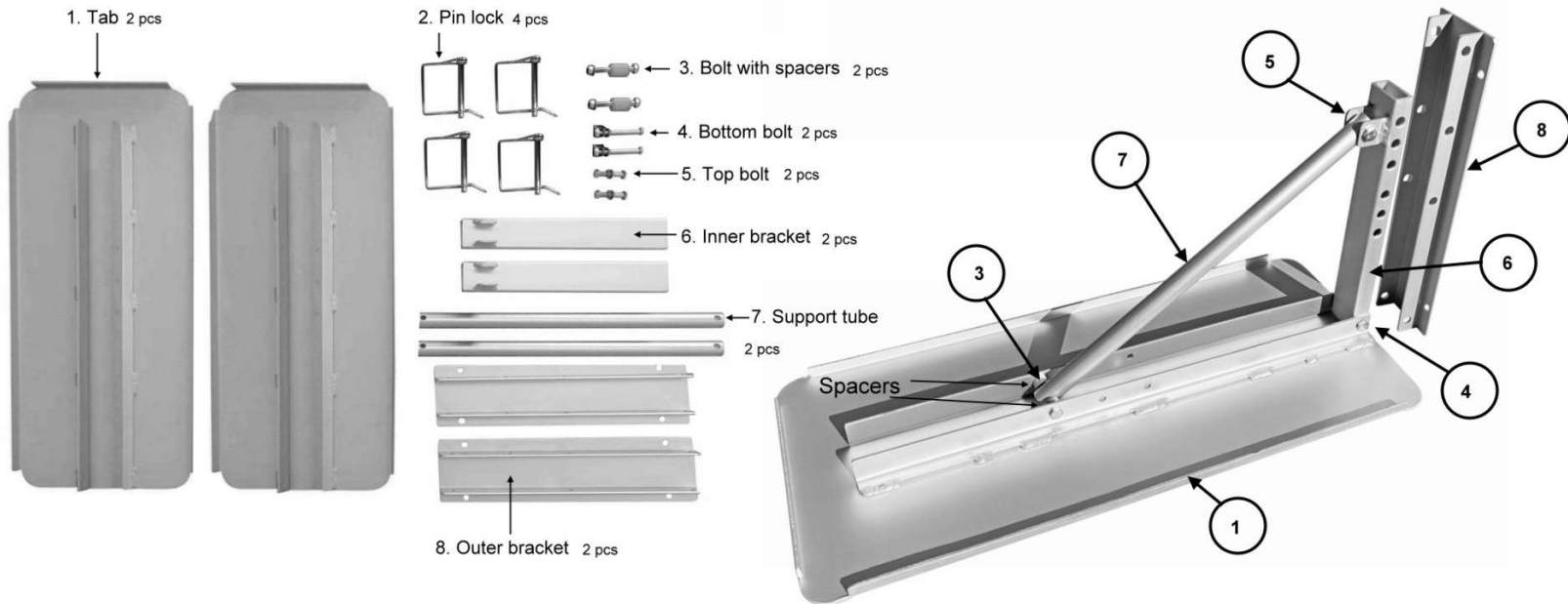
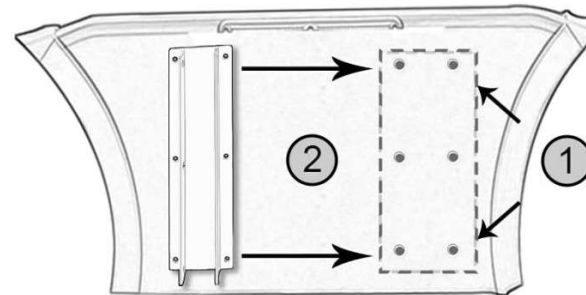

2. Fix outer bracket to transom using stainless steel bolts. At least 2 bolts are needed to secure outer bracket. Best if 4 to 6 bolts are used.

Quick Tip:
Apply optional silicone into holes drilled into transom, before installing bolts through holes.

IMPORTANT - BEFORE DRILLING HOLES INTO THE TRANSOM:

1. To find best possible location, assemble both tabs and place against transom of fully inflated boat. Mark location with pen or painters tape.
2. Tabs should be installed in such ways that bottom of tabs level with bottom of transom, or at least slightly higer.
3. Make sure that tabs are not on a way of outboard motor, and not scratching against rear tubes. Tabs should be at least 1/2" from tubes surfaces.